



Model 88S Security System

Print Invisible, UV Light Readable.

Product Security and Counterfeit Avoidance.



The Model 88S Security is targeted at product traceability, security, counterfeit avoidance and brand protection applications. Ensure the product in question is truly your product.

Print real-time One-Dimensional (1D) and Two-Dimensional (2D) barcodes—Datamatrix, QR Code and other custom dot codes on demand. Barcodes can be encrypted with company and product specific serialization information.

Invisible ink prints clear and invisible—can only be seen when fluoresced with UV light. The codes and marks light up a bright blue color. Printing is permanent to a wide range of substrates—drying immediately on metal, glass, plastic and more.

Invisible codes survive high temperatures and remain invisible when exposed to high temperatures, steam processes such as that used for pasteurizations or sterilization processes.

Typical applications mark and code one, two or 3 shifts per day or 24/7 operations, five to seven days per week, averaging 4,000 – 8,760 hour annual operation. Utilize integrated RS232 and programmable inputs/outputs for remote control and communications.

Systems are simplified to allow anyone to operate, minimizing operator touches, extending time between human interaction.



PRINT CAPABILITIES

SECURITY PRINTING—Print with Invisible, UV Read ink and other Security Ink options.

LINES OF PRINT—1, 2, 3, 4 or 5 lines of text, graphics and barcodes.

IMAGE HEIGHT—from .06" (1.5 mm) to .75" (19 mm).

NON-CONTACT PRINTING—ink throw distances from .5" (12 mm) up to 2" (50 mm).

PRINT SPEEDS—up to 1500 feet/minute (470 meters/minute) for a single line of print, up to 345 feet/minute (108 meters/minute) for two lines of print, up to 173 feet/minute (54 meters/minute) for three lines of print, up to 119 feet/minute (36 meters/minute) for four lines of print and up to 114 feet/minute (35 meters/minute) for five lines of print.

- **CleanStart™** —automatically cleans printhead eliminating daily and weekly cleanings.
- **10.4" Color Touch Screen**—always on, vivid display with large intuitive buttons and status indicators.
- **OneTouch™** —single step operator functions reduce operator steps.
- **Large Volume Ink Tanks**—extend time between fluid additions to weeks or months.
- **On-the-Fly External Ink Filling**—accomplished in less than a minute with no waste.
- **AutoOff™ Go Home Button**—automate and eliminate time consuming end of day manual routines.

**THE CLOSER YOU LOOK,
THE BETTER BESTCODE LOOKS!**



Model 88S Specifications

Technology	Continuous Ink Jet (CIJ) Technology, Single Printhead Control
User Interface	10.4" (264 mm) Color LCD, Touch Screen, Icon based – Graphical User Interface (GUI)
Lines of Print	1 - 5 Lines, 25 Pixel
Print Fonts	5, 7, 9, 12, 16, 19, 25, 32
Adjustable Print Height	.06" (1.5 mm) - .50" (12 mm)
Optional Print Height	.10" (2 mm) - .75" (19 mm)
Print Speed	1 Line: 1500 feet/minutes (470 meters/minute), 2 Line: 345 feet/minutes (108 meters/minute), 3 Line: 173 feet/minutes (54 meters/minute), 4 Line: 119 feet/minutes (36 meters/minute), 5 Line: 114 feet/minutes (35 meters/minute)
Ink Throw Distance	True Non-Contact Printing, .5" (12 mm) - 2" (50 mm)
Electronic Hardware	32 Bit ARM 9, 208 Mhz Processor
Memory Storage	4 GByte Solid State Drive, 15 MByte Flash, 128 Mbyte RAM, USB Interface (thumb drive)
Machine Interface	RS232, Ethernet
Inputs	1 Photocell, 1 Photocell or Programmable Input, 1 Shaft Encoder, 8 Field programmable inputs, Remote Message Selection option – 256 possible selections
Outputs	4 Alarm Outputs, 1 Relay Output
Enclosure	Stainless Steel Enclosure
Ingress Protection	IP65
SmartFilter™ Life	10,000 hours
Operating Environment	Temperature: 32°- 122° F (0°- 50°C), % Relative Humidity: 10 - 90% (non-condensing)
Electrical Requirements	Auto Ranging: 100 - 240 VAC (3 Amp), Frequency 50 - 60 Hz, Power Consumption: 50 W
Compliance	CE Certified, RoHS Compliant
Message / Code Creation	Dynamic Message Storage (over 1000 Messages), WYSIWYG Message Editing, Drag / Drop Field Based Formatting, Multi-National (Unicode) Character Printing, Download Fonts, Integrated Font Editor, Real and Expiration Time and Date, Shift and Rollover Functions, Product and Batch Counting, Remote Count Resets, Download Graphics and Integrated Graphic Editor, Continuous and Repeat Print, Auto Reverse / Traverse Print
Operation Features	Icon Based Operation, Single Button Start, Single Button Stop / Power Off, Password Security, Automatic Diagnostics, Error and Activity Logs, Service Reminders, Backup / Restore Functions, USB Load Firmware Updates, All Operator Languages, Download Languages
Ink Delivery	SmartFill™ Ink Bottle: 32 oz (946 ml), SmartFill™ Makeup Bottle: 32 oz (946 ml)
Fluid Capacity	Ink Capacity: 68 oz (2 liters), Makeup Capacity: 102 oz (3 liters)
Ink Types	Quick Dry to Immediate (1 second or less)
Ink Colors	Invisible, UV Read with UV Light - lights up Bright Blue
Specialist Inks	Thermo Color Change, Wet Bottle, Caustic Washable, Plastic, Eco-Friendly, Alcohol Resistant, Military Spec, Wet Bottle
Printhead Umbilical	10 feet (3 meters), 15 feet (4.5 meters) option
Printhead Options	Right Angle Printhead
Printing	Printhead Orientation – Omnidirectional
Weight	45 lbs (20 kg)
Optional Accessories	Alarm Beacon, Photocells, Mountings, Shaft Encoder, AirFlow™ Positive Air Kit (for high dust), Printhead Wash Station

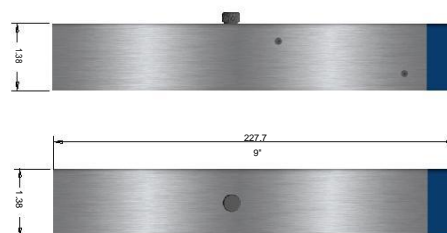
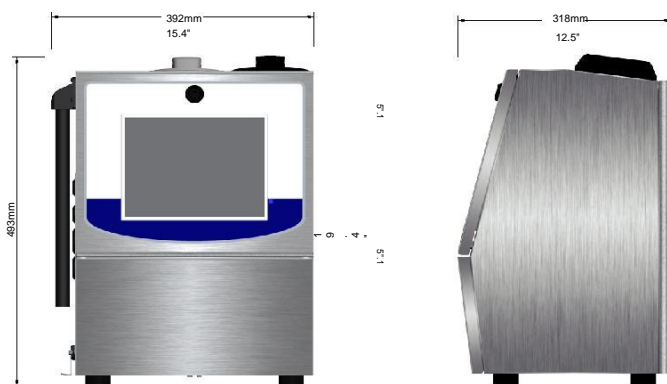

By request, BestCode can adapt hardware and software to meet specific application demands.